



Smart Inflate™
Blood Pressure Monitor

Instruction Manual

Features:

- Smart Inflate™ Technology
- Auto memory for up to 60 readings
- One-Touch Operation
- Pre-Programmed Alert Feature
- Easy-to-read Display
- Time and Date Display

Table of Contents

Smart Inflate™ measuring technology	3
Statement of accuracy	3
About blood pressure	3
Blood pressure standard	4
Blood pressure fluctuation	4
Before taking a measurement	5
Name / function of each part.	6
Display explanation	7
Installing batteries.	7
Recalling memory.	8
Time adjustment	8
Applying the arm cuff.	9
Taking a measurement	10
Troubleshooting	11
Cautionary notes	11
Specifications	12

—— **Smart Inflate™ Measuring Technology** ——

This Physio Logic™ monitor uses trend-setting Smart Inflate™ Technology to detect your blood pressure. With one touch of a button, it will automatically start to inflate and determine your blood pressure by analysing your pressure oscillations while inflating. When the measurement is completed, the device will automatically deflate the cuff and display your systolic, diastolic, and pulse. Measurement time is significantly shortened and user comfort is greatly enhanced.

———— **Statement of Accuracy** ————

Blood pressure measurements determined with Physio Logic™ are equivalent to those obtained by a trained observer using cuff / stethoscope auscultation method, within the limits prescribed by the American National Standard for Electronic or Automated Sphygmomanometers (ANSI/AAMI).

———— **About Blood Pressure** ————

Blood pressure is the pressure exerted on the arterial wall while blood flows through the arteries. The pressure measured when the heart contracts and sends blood out of the heart is systolic (highest). The pressure measured when the heart dilates with blood flowing back into the heart is called diastolic (lowest) blood pressure.

High blood pressure's strong correlation with cardiovascular diseases and high morbidity has made measuring blood pressure a necessity of identifying those at risk.

Blood Pressure Standard

The Joint National Committee on prevention, detection, evaluation, and treatment of high blood pressure has developed a blood pressure standard, according to which areas of low and high risk blood pressure are identified. This standard is a guideline as blood pressure varies among different people and different age groups...

It is important that you consult with your physician regularly. Your physician will tell you your normal blood pressure range as well as the point at which you will be considered at risk.

Blood Pressure for Adults Age 18 and Older			
Category	Systolic (mm Hg)		Diastolic (mm Hg)
Optimal	<120	and	<80
Normal	<130	and	<85
High-normal	130-139	or	85-89
Hypertension Stage 1	140-159	or	90-99
Hypertension Stage 2	160-179	or	100-109
Hypertension Stage 3	>180	or	>110

Blood Pressure Fluctuation

Blood pressure fluctuates all the time! You should not be overly worried if you encounter two or three measurements at high levels. Blood pressure changes over the month and throughout the day.

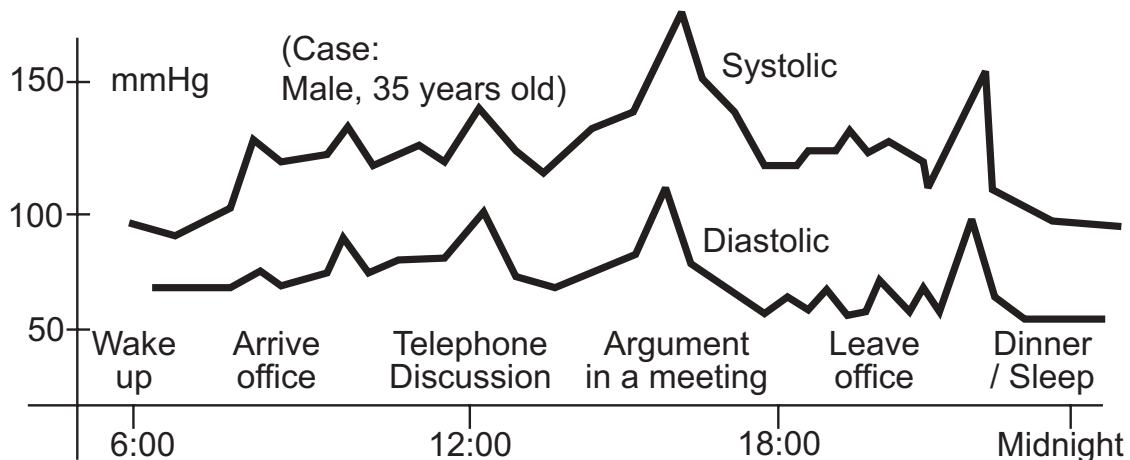

Before Taking a Measurement

To help you obtain more accurate readings:

- Urinate if necessary.
- Remove any clothing and jewellery from your left arm. Placing the cuff on anything other than bare skin can result in an inaccurate reading.
- Sit in a comfortable position with your legs and ankles uncrossed and your back supported.
- Sit quietly for 15 minutes before measuring your blood pressure.
- If you need to retake a reading, wait at least 5 minutes to allow your circulation to return to normal.
- Pick a time of day, and take your blood pressure at about the same time every day. Since your blood pressure varies at different times of the day, this will make it easier for you to compare your daily blood pressure readings. A good time to take your blood pressure is in the morning, before breakfast.
- Don't smoke, eat or exercise for 30 minutes before taking your blood pressure. These activities can change your blood pressure.
- Do not measure your blood pressure immediately after consuming a large meal. To obtain more accurate readings, please wait one hour before measuring.
- Only take your blood pressure in a quiet place and when you are relaxed. Don't take your blood pressure when you are under stress. Any stress will raise your blood pressure.
- Position your arm so that the cuff is at the level of your heart.
- If the monitor is stored at very low temperature (near freezing), place it in a warm location for at least one hour before using it.

Name / Function of Each Part

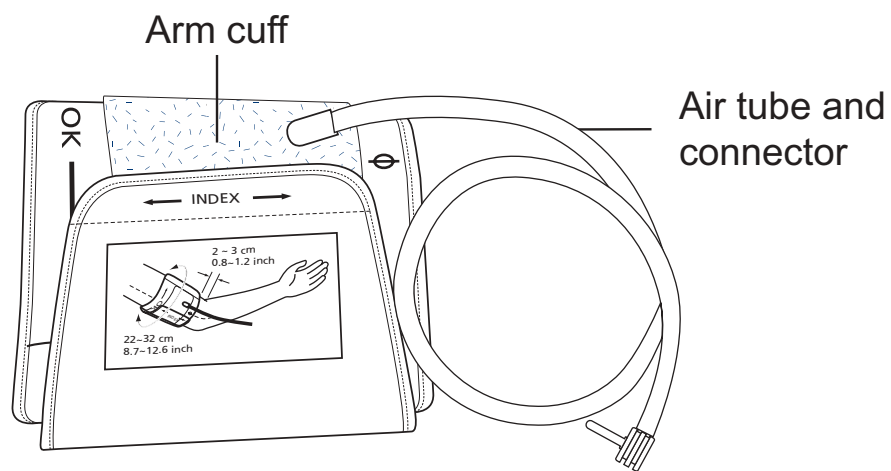
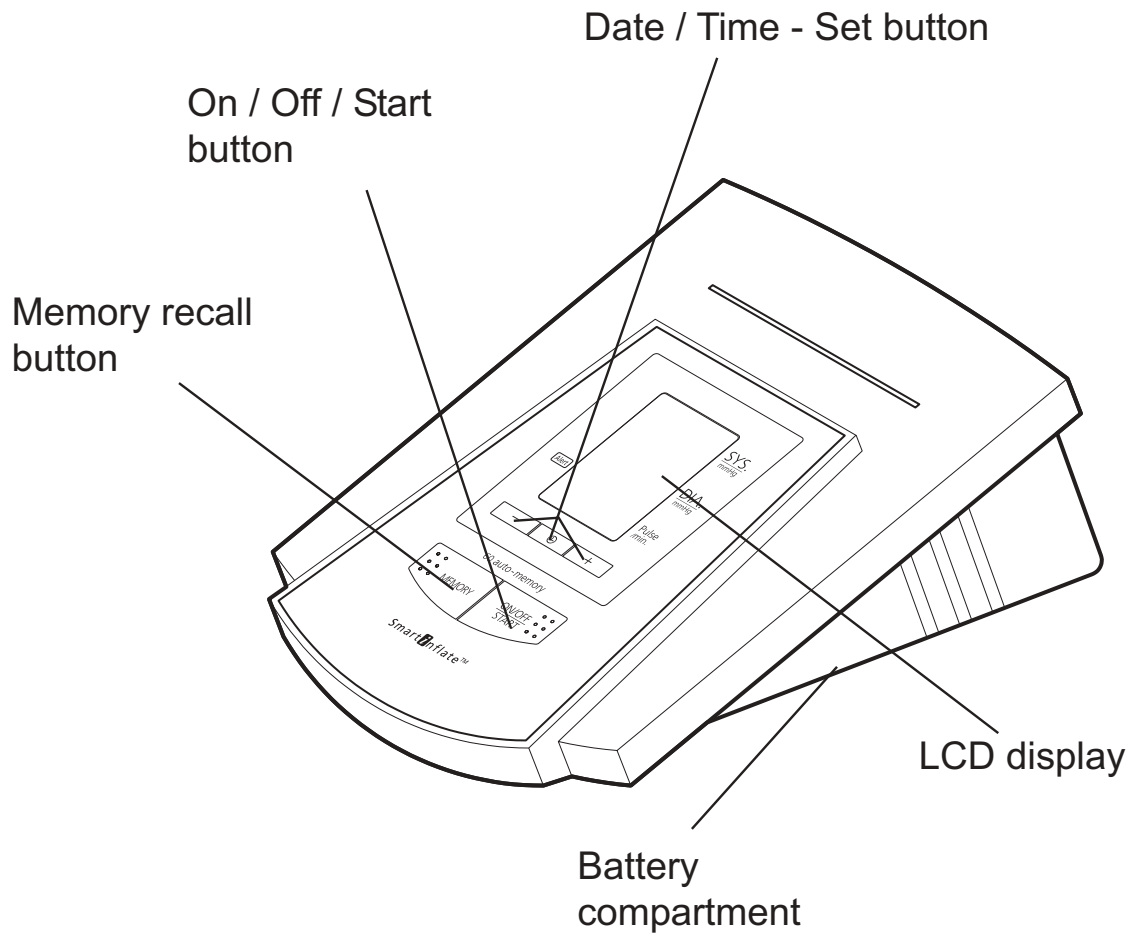

Display Explanation

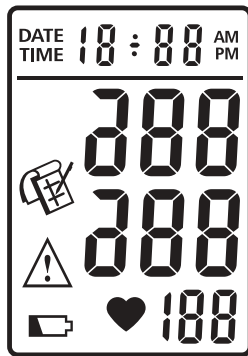

Date and time

Systolic pressure

Diastolic pressure

Pulse rate



Appears when measurement value is stored in memory or is recalled from memory.



Appears when blood pressure reading is higher than 160 mmHg (sys.) or 95 mmHg (dia.)



Appears when batteries should be replaced.



Shows the pulse rate per minute.



Occurs when an error was made during measurement.

Installing Batteries

1. Press down and lift the battery cover in the direction of the arrow to open the battery compartment.
2. Install 4 “AA” 1.5 V Alkaline batteries according to the indication inside the compartment.
3. Replace the battery cover by inserting the bottom tabs first, then push in the top end of the battery cover.

Replace batteries when:

1. Low battery icon appears on display.
2. The On / Off / Start button is pushed and nothing appears on display.

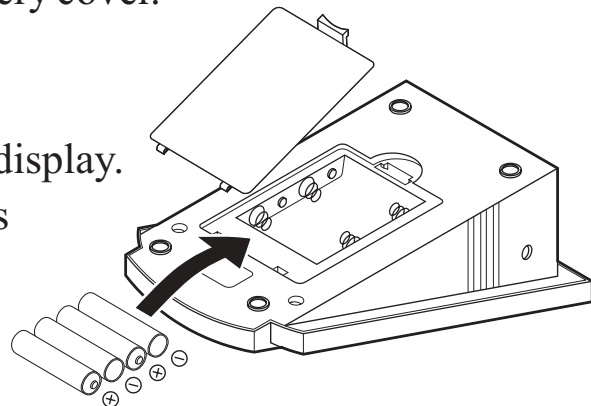

Recalling Memory

1. To recall stored blood pressure readings from memory, simply press the Memory button. The last set of memorized readings will be displayed.
2. Another press of the Memory button will recall the previous set of readings.

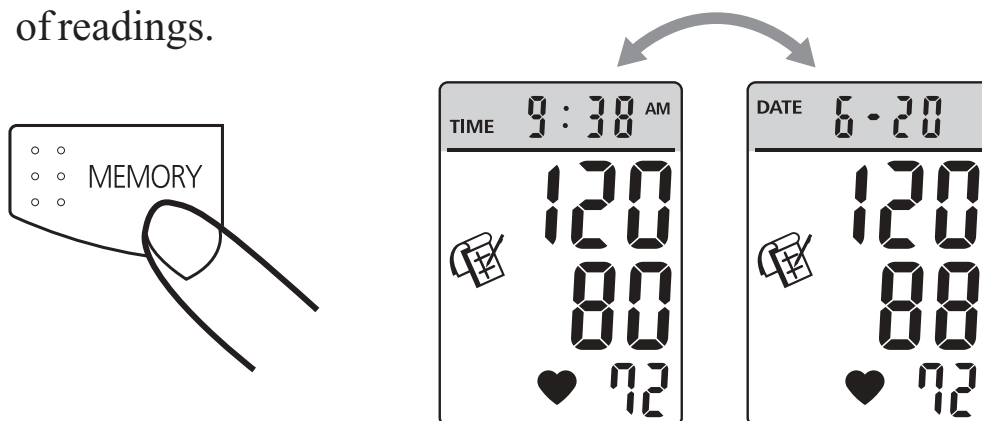

Time Adjustment

1. Press and hold the (⊖) button for more than 3 seconds to enter Time Adjustment Mode. The display will show a blinking Month.

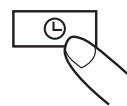

Hold for more than 3 seconds

2. Press the “+” or “-” to change the Month.

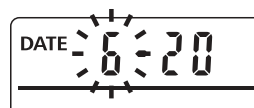

Blinking month

3. Press the (⊖) button again to confirm the entry.

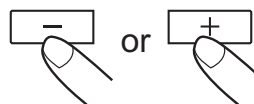

Changing month

4. The display will then show a blinking Date, followed by Hour and Minutes. Repeat steps 2 and 3 to adjust the date/time setting.

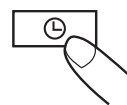

Confirm the entry

Applying the Arm Cuff

1. Insert the cuff's connecting tube into the unit.
2. Unwrap the arm cuff, leaving the "Index" end of the cuff through the D-ring of the cuff.

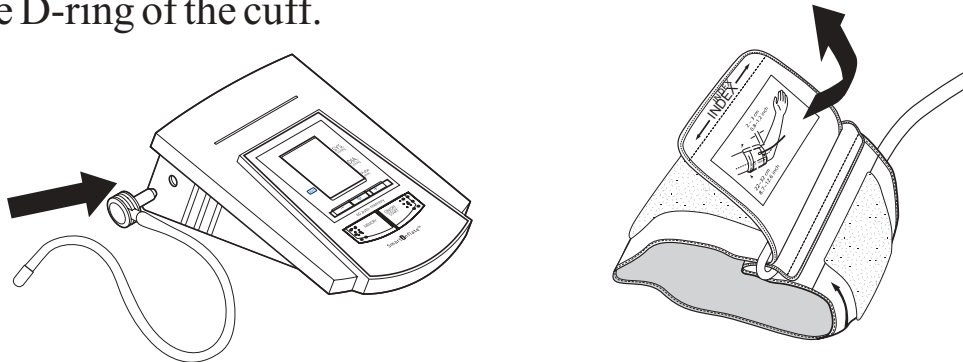

3. Put your left arm through the cuff loop. Position the artery mark (ϕ) at the middle of your arm above the elbow, in line with your middle finger. Tighten the cuff by pulling the "Index" end of the cuff (snug, not tight).

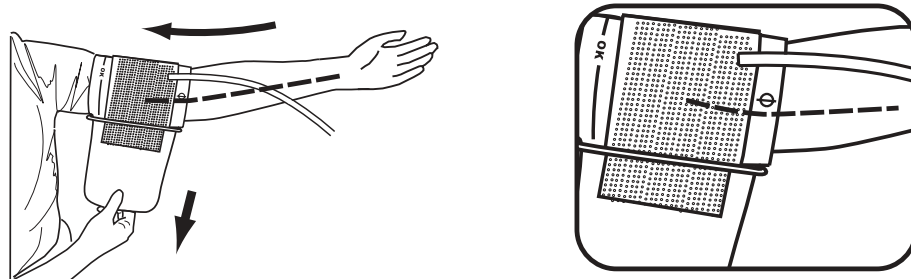

4. Turn your left palm upward and place the edge of the arm cuff at approximately 2 to 3 cm (0.8" - 1.2") above the inner side of the elbow joint.

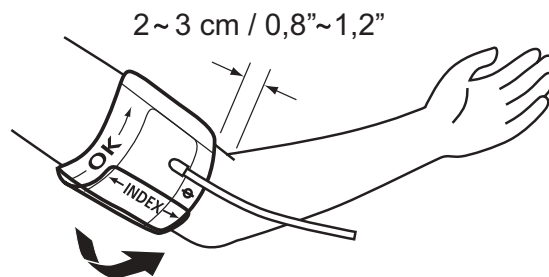

5. If the Index line falls within the OK range, indicated at the edge of the cuff, this cuff is suitable for your use. If the Index line falls out of the OK range, you may need a different size cuff.

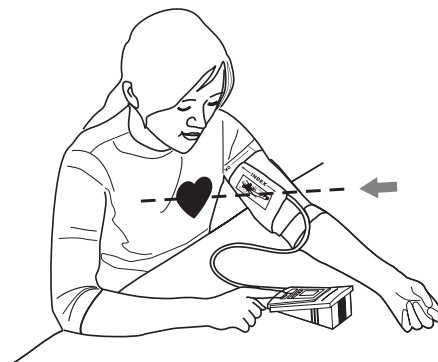

Taking a Measurement

1. Press the On / Off / Start button. All displays will appear for approximately one second before returning to “0”.
2. The unit will automatically start to inflate and begin to measure your blood pressure. During inflation, a changing measure of the cuff pressure will be shown on the display.

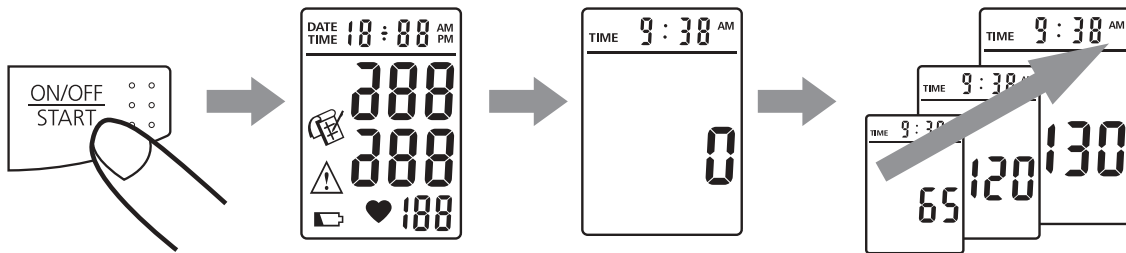

3. When pressure reaches your systolic blood pressure, the monitor will deflate the cuff automatically. When the monitor completes the measurement, it will display and save your systolic, diastolic, and pulse readings. Up to 60 memories can be saved.



This monitor has a built-in alert feature. If your blood pressure reading is higher than 160 mmHg (SYS) or 95 mmHg (DIA), an alert icon will show on the display. This reminds you that your measurement fell outside of the high blood pressure limits. If this should persist, it is recommended to see your physician.

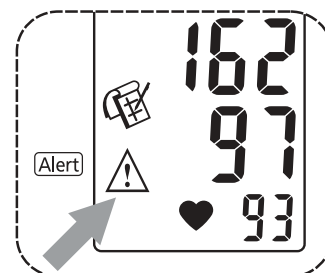

4. Measurement is now completed. Press the On / Off / Start button to turn the unit off. If no button is pressed, the unit will shut off automatically in 1 minute.

Troubleshooting

Symptom: No display when the On / Off / Start button is pressed.

Correction: If the batteries have run down, replace them with new alkaline batteries. If the batteries are not in the correct position, re-insert them with the correct polarities.

Symptom: **EE** mark shown on display or the blood pressure value is displayed excessively low (high).

Correction: Wrap the cuff properly so that it is positioned correctly. If you talked or moved during the measurement, measure it again quietly.

Note: If the unit does not work, please call our consumer information line at 1-800-363-2381. Under no circumstance should you disassemble the unit and attempt repairs.

Cautionary Notes

1. Avoid extreme temperatures, humidity, and direct sunlight. Avoid dropping or strongly shocking the main unit, and protect it from dust.
2. Clean the blood pressure monitor body and the cuff carefully with a slightly damp, soft cloth. Do not press. Do not wash the cuff or use chemical cleaner.
3. Remove the batteries when the unit is not used for a long time.
4. The unit should not be operated by children.
5. This device might not be suitable for use by people with common arrhythmias, such as atrial or ventricular premature beats or atrial fibrillation. It is not designed for ambulatory use.

Specifications

Measurement method	: Oscillometric
Measurement range	: Pressure: 20 to 280 mmHg ; Pulse: 40 to 180 beats / min.
Pressure sensor	: Semi conductor
Accuracy	: Pressure: ± 3 mmHg; Pulse: ± 5 % of reading
Inflation	: Pump driven
Deflation	: Automatic pressure release valve
Memory capacity	: 60-set memory
Auto-shut-off	: One minute after last button operation
Operation temperature	: 10°C to 40°C (50°F to 104°F)
Operation humidity	: 40 to 85 % HR maximum
Storage temperature	: -5°C to 60°C (23°F to 140°F)
Storage humidity	: 10 to 95 % HR maximum
Power source	: 6 V DC, four LR06 (AA) 1.5 V batteries
Dimensions	: 105 (L) x 160 (L) x 68 (H) mm
Weight	: 350 g (G.W.) (without batteries)

** Specifications are subject to change without notice.*

Consumer Info-Line
1-800-363-2381



AMG MEDICAL INC.
8505 Dalton, Montreal, QC H4T 1V5
www.amgphysiologic.com
www.amgmedical.com